

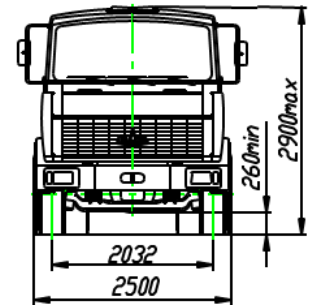

Truck mounted aerial lift reach vertical min.20.0 m
Belarus MAZ-533702-246-700

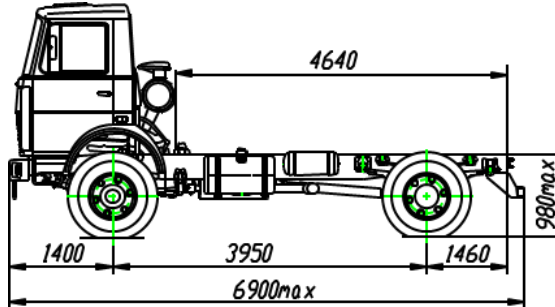

| | |
|---|------------------------------|
| WHEEL FORMULA: | 4×2 |
| LOAD PARAMETERS: | |
| Chassis payload carried, kg: | 11650 |
| Mass of the equipped automobile, kg | 6350 |
| Load on a road by the equipped automobile, kg: | 4170 |
| - through tyres of front axle | 2180 |
| - through tyres of the rear axle. | |
| Gross mass of automobile, kg | 18000 |
| Load on a road by automobile by gross mass, kg: | |
| - through tyres of the front axle | 6500 |
| - through tyres of the rear axle. | 11500 |
| Max rise overcome by the automobile by gross mass, % not less | 25 |
| ENGINE: | |
| Model | YAMZ-236HE2T (euro-2) |
| Diesel, 6 cylinder, V-type, with turbo-supercharging and intercooler. | |
| Displacement, l | 11,15 |
| Power, kW (hp). | 169 (230) |
| - at frequency of rotation, min ⁻¹ . | 2100 |
| Max torque, N m | 882 |
| - at frequency of rotation, min ⁻¹ | 1100-1300 |
| Cooling system: | |
| liquid, closed type with forced circulation of a cooling liquid expansion tank and coupling of fan disconnecting. | |
| Lubrication system: | |
| mixed with the water-to-oil cooler, filter with the paper element and filter of centrifugal clearing. | |

Head Office: 3-1136 Centre St, Ste. 124, Thornhill, ON, L4J 3M8, Canada

Warehouse: 2682 Highway 34, Hawkesbury, Ontario, K6A 2R2, Canada

Tel: 1-855-2GO-4MTZ (1-855-246-4689) **Fax:** 1-647-933-9066 **E-mail:** info@mtzequipment.com **Web:** www.mtzequipment.com

| | |
|--|---|
| Fuel system: in-line fuel injection pump, filters of primary and secondary clearing. Fuel tank, l. | 200 |
| CLUTCH: Friction, dry, single disk. The hydraulic drive with pneumatic booster. | YAMZ-182 |
| GEARBOX: Mechanical. Quantity of transfers is 5 with synchronizers on all transmissions, except of backward motion and the first transmission. | ЯМЗ-2361 |
| DRIVING AXLE: Rear, two-stage with central reducer and wheel cylindrical transmissions of planetary type. There is a lock of interwheel differential. Maximum speed of automobile, km/h | U₀=6,94 85 |
| FRONT AXLE: Controlled type, beam of I-section axis with rotary cams fixed on needle bearings. | |
| FRAME: From stamped parts. In front and rear part there is a towing fork. | |
| FRONT SUSPENSION: Dependent, on longitudinal semielliptical springs, with two hydraulic double-side operation shock absorbers of telescopic type. | |
| REAR SUSPENSION: Dependent, on two main and two additional springs, stabilizer of cross-sectional stability. | |
| WHEELS: Disk, fasten by 10 nuts. Quantity: Spare wheel: | 8.5-20 6 1 |
| TYRES: Pneumatic, with road figure of the protector. Dimensionality: Index of payload capacity: Index of speed: | 12.00R20 150/146 J |
| STEERING GEAR: With the hydraulic booster. The control column is regulated on altitude, angle of declination, is supplied with anti-thief and trauma protection devices. | |
| BRAKE SYSTEM: Pneumatic, with the separate drive of front and rear wheels. | |
| WORKING: Working brake is foot type, brake mechanisms are drum type. ABS. | |
| PARKING: Influences on rear wheels from spring power accumulators having the pneumatic drive. | |

Head Office: 3-1136 Centre St, Ste. 124, Thornhill, ON, L4J 3M8, Canada

Warehouse: 2682 Highway 34, Hawkesbury, Ontario, K6A 2R2, Canada

Tel: 1-855-2GO-4MTZ (1-855-246-4689) **Fax:** 1-647-933-9066 **E-mail:** info@mtzequipment.com **Web:** www.mtzequipment.com

| | |
|---|-------------|
| <p>AUXILIARY: Throttling type, has a throttle plates installed in the engine exhaust pipelines and controlled by air cylinder.</p> | |
| <p>ELECTRIC EQUIPMENT SYSTEM: Single-wire, direct current with nominal voltage 24V. The negative pole energy of the accumulator battery is connected to the frame. There are 2 batteries by capacity of 190 Amp-hrs. Generator: 28V, 80A. Starter: 24V, 5,5kW.</p> | |
| <p>CABIN: All-metal, unsprung, two-place, two-door, can be pushed forward on angle of 55°.</p> | |
| <p>WIND SCREEN: Triplex with electrical windshield washer. - capacity of electrical windshield washer, l</p> | 10.0 |
| <p>The installing of superstructure (for guarantee saving) is approved by manufacturer's technical departments. The manufacturer reserves the right to itself to make modifications directed on improving of the automobile parameters.</p> | |

Head Office: 3-1136 Centre St, Ste. 124, Thornhill, ON, L4J 3M8, Canada

Warehouse: 2682 Highway 34, Hawkesbury, Ontario, K6A 2R2, Canada

Tel: 1-855-2GO-4MTZ (1-855-246-4689) **Fax:** 1-647-933-9066 **E-mail:** info@mtzequipment.com **Web:** www.mtzequipment.com